



City of Lakewood
Planning Commission

(216) 529-6630
planning@lakewoodoh.gov

AGENDA
PLANNING COMMISSION
CITY OF LAKEWOOD
12650 DETROIT AVENUE
THURSDAY
APRIL 2, 2026

PRE-REVIEW MEETING
5:30 P.M.
AUDITORIUM

REVIEW DOCKET ITEMS

REVIEW MEETING
6:00 P.M.
AUDITORIUM

1. ROLL CALL
2. APPROVE THE MINUTES OF THE THURSDAY, MARCH 5, 2026 MEETING
3. OPENING REMARKS

OLD BUSINESS

NEW BUSINESS

CONDITIONAL USE

4. Docket No. 04-07-26 OD
2035 Quail St.
Birdtown Brewing Outdoor Dining

Ryan Grammerstorf, **Birdtown Brewing**, applicant requests the review and approval for a conditional use permit to operate seasonal outdoor dining for a new private outdoor bar, pursuant to section 1129.13 – supplemental regulations for outdoor/ seasonal dining facility. (Ord. 33-2022. Passed 11-21-22.) The property is in the R2 Zoning district and the Mixed Use Overlay District

5. Docket No. 04-08-26 SOD
15314 MADISON AVE
Mars Bar Sidewalk Dining 2026

George Gountis, **Mars Bar**, applicant requests the review and approval for a conditional use permit to operate seasonal outdoor dining on a public sidewalk, pursuant to section 1129.13 – supplemental regulations for outdoor/ seasonal dining facility. (Ord. 33-2022. Passed 11-21-22.) The property is in the C2, Commercial Retail district.

6. Docket No. 04-09-26 SOD
15527 MADISON AVE
Barrio Sidewalk Dining 2026

Sean Fairbairn, **Barrio**, applicant requests the review and approval for a conditional use permit to operate seasonal outdoor dining on a public sidewalk, pursuant to section 1129.13 – supplemental regulations for outdoor/ seasonal dining facility. (Ord. 33-2022. Passed 11-21-22.) The property is in the C2, Commercial Retail district.

7. Docket No. 04-10-26 SOD
17112 DETROIT AVE
Cleveland Vegan Sidewalk Dining 2026

Laura Ross, **Cleveland Vegan**, applicant requests the review and approval for a conditional use permit to operate seasonal outdoor dining on a public sidewalk, pursuant to section 1129.13 – supplemental regulations for outdoor/ seasonal dining facility. (Ord. 33-2022. Passed 11-21-22.) The property is in the C2, Commercial Retail district.

8. Docket No. 04-11-26 SOD
14224 Madison Ave
The Pastimes Café Sidewalk Dining 2026

Evan Laisure, **The Pastimes Café** applicant requests the review and approval for a conditional use permit to operate seasonal outdoor dining on a public sidewalk, pursuant to section 1129.13 – supplemental regulations for outdoor/ seasonal dining facility. (Ord. 33-2022. Passed 11-21-22.) The property is in the C3, Commercial General district.

COMMUNICATION

9. Docket No. 04-12-26

Communication from David Baas, Assistant Director of Planning and Development
Renewal of Conditional Use Permit for Outdoor Seasonal Dining on private property.

The following businesses received approval for renewal of a Conditional Use permit **for the year 2026** through the annual administrative review by the Department of Planning and Development:

- | | |
|------------------------------|----------------------------------|
| 1. 18622 DETROIT AVE | AROUND THE CORNER |
| 2. 15527 MADISON AVE | BARRIO- REAR DINING AREA |
| 3. 15315 MADISON AVE | BUCKEYE BEER ENGINE |
| 4. 18260 DETROIT AVE | CILANTRO TAQUERIA |
| 5. 16512 DETROIT AVE | COZUMEL MEXICAN RESTAURANT |
| 6. 15322 DETROIT AVE | CRUMB & SPIGOT |
| 7. 15012 DETROIT AVE | DAVE'S HOT CHICKE |
| 8. 11801 CLIFTON BLVD | DINERBAR ON CLIFTON |
| 9. 1528 W. 117TH ST. | DUNKIN' DONUTS |
| 10. 11922 MADISON AVE | EAST END BISTRO |
| 11. 11904-08 DETROIT AVE | FIVE O'CLOCK LOUNGE |
| 12. 14600 DETROIT AVE | FORAGE PUBLIC HOUSE |
| 13. 17103 DETROIT AVE | GAME ON LAKEWOOD |
| 14. 17415 NORTHWOOD | GARDEN BAR (@ St. James) |
| 15. 18515 DETROIT AVE | GEORGETOWN RESTAURANT |
| 16. 14013 DETROIT AVE | GETGO |
| 17. 13603 MADISON AVE | HAKO SUSHI AKA AJI NOODLE |
| 18. 13333 MADISON AVE | HAMMER AND NAILS |
| 19. 14319 MADISON AVE | HARLOW'S PIZZA |
| 20. 15400 DETROIT AVE | HUMBLE WINE BAR |
| 21. 18120 SLOANE AVE. | IMMIGRANT SON BREWERY |
| 22. 18405 DETROIT AVE | INDIA GARDEN |
| 23. 16306 DETROIT AVE | JERSEY MIKE'S SUBS |
| 24. 14725 DETROIT AVE | JIMMY JOHN'S |
| 25. 11750 MADISON AVE | JOE'S DELI |
| 26. 12420 MADISON AVE | K-TOWN RESTAURANT AND MARKET |
| 27. 16900 DETROIT AVE | LAKESWOOD TRUCK PARK |
| 28. 14018 DETROIT AVE | LIZARDVILLE |
| 29. 15314 MADISON AVE | MARS BAR CAFÉ – REAR DINING AREA |
| 30. 15605-07 1/2 DETROIT AVE | MERRY ARTS PUB & GRILLE |
| 31. 16934 DETROIT AVE | MIDTOWN BOOTHS |
| 32. 18401 DETROIT AVE | MOLTO BENE ITALIAN RESTAURANT |
| 33. 17014 MADISON AVE | MULLEN'S ON MADISON |
| 34. 15613 DETROIT AVE | NATURE'S OASIS |
| 35. 14701 DETROIT AVE | PANERA |
| 36. 12700 LAKE AVE | PIER W |
| 37. 16719 DETROIT AVE | PLANK ROAD TAVERN |
| 38. 14115 DETROIT AVE | RAISING CANE'S CHICKEN FINGERS |
| 39. 14900 DETROIT AVE | ROZI'S WINE HOUSE |
| 40. 17514 DETROIT AVE | SACRED HOUR SPA@ST JAMES |
| 41. 14523 MADISON AVE | SARITA A RESTAURANT |

- | | |
|-----------------------|--------------------------|
| 42. 14701 DETROIT AVE | SAUCED TAPROOM & KITCHEN |
| 43. 15027 DETROIT AVE | STARBUCK'S COFFEE |
| 44. 15320 DETROIT AVE | TAPSTER CLEVELAND |
| 45. 13368 MADISON AVE | THE BOTTLEHOUSE BREWERY |
| 46. 11926 MADISON AVE | THE FLYING RIB |
| 47. 15326 DETROIT AVE | VOODOO TUNA |
| 48. 16918 DETROIT AVE | WINE DIVE BAR |
| 49. 14018 DETROIT AVE | WINKING LIZARD |

ADJOURN

"Individuals with disabilities, who require accommodations for participation in meetings, must request accommodations at least 3 business days ahead of the scheduled meeting. Contact Michelle Nochta at (216) 529-5906 michelle.nochta@lakewoodoh.gov."



City of Lakewood
Planning Commission

(216) 529-6630
planning@lakewoodoh.gov

Application Cover Page

Docket No.: 04-07-26

Permit No.: PC26-000004

Applicant Name: Ryan Grammerstorf, Birdtown Brewing

Project Address: 2035 Quail St.

Project Name: Birdtown Brewing Outdoor Dining

Proposal: The review and approval for a conditional use permit to operate seasonal outdoor dining for a new private outdoor bar, pursuant to section 1129.13 – supplemental regulations for outdoor/ seasonal dining facility. (Ord. 33-2022. Passed 11-21-22.) The property is in the R2 Zoning district and the Mixed Use Overlay District

9.00X

Handwritten signature: *Alfred*

Project: 48 seat Outdoor Dining Patio

Applicant: Birdtown Brewing

Address: 2035 Quail Street, Lakewood OH

Prepared For: City of Lakewood Department of Planning and Development

Date: March 10, 2026

Project Overview:

This proposal is for the development of a 48-seat outdoor dining patio to serve patrons of Birdtown Brewing located at 2035 Quail Street in Lakewood. The patio will provide additional seating capacity for the restaurant and enhance the outdoor environment associated with the business.

The proposed patio will be located on the north side of the existing building and will function as an extension of the indoor dining area. The space will be used for outdoor dining consistent with the primary restaurant operation.

The patio is designed to accommodate approximately 48 seats, consisting of a combination of four-person and six-person dining tables. The seating arrangement will allow comfortable dining while maintaining adequate space for customer circulation and staff service.

Tables will be positioned to ensure clear walking paths throughout the patio and to maintain safe access to building entrances and exits. The layout will comply with applicable accessibility and safety standards.

The patio area will include the following features:

- Commercial-grade outdoor tables and chairs
- Four-person dining tables arranged throughout the patio
- Decorative planters and landscaping to enhance the appearance of the space
- A perimeter railing or barrier to define the patio area
- Exterior lighting to provide adequate visibility during evening hours

The outdoor patio will operate during the restaurant's regular business hours. Food and beverages will be served by restaurant staff as part of normal restaurant operations.

Staff will maintain the patio area, including routine cleaning and proper waste management through the existing restaurant service facilities.

Accessible seating will be provided, and an ADA-compliant route will connect the patio to the restaurant entrance to ensure access for all patrons.

The proposed 48-seat outdoor patio on our north side of the building will expand dining capacity while enhancing the functionality and appearance of the property. The project will comply with all applicable planning, zoning and building regulations.



BIRDTOWN BREWING

BRANDING & SIGNAGE CONCEPT DESIGN

LOGO REFINEMENT

SELECED BRAND DIRECTION

BIRDTOWN
BREWING
LAKEWOOD, OH

WORDMARK



CREST

LOGO REFINEMENT

CREST + WORDMARK



CREST + WORDMARK



CREST + WORDMARK

BRAND ACTIVATIONS

HAT & T-SHIRT



SIGNAGE QUAIL STREET ENTRANCE & WALL SIGN

RENDERING — SIGNAGE OPPORTUNITY



SIGNAGE ENTRANCE SIGN

RENDERING — SIGNAGE OPPORTUNITY



SIGNAGE LOCATION IDEAS

PLAN

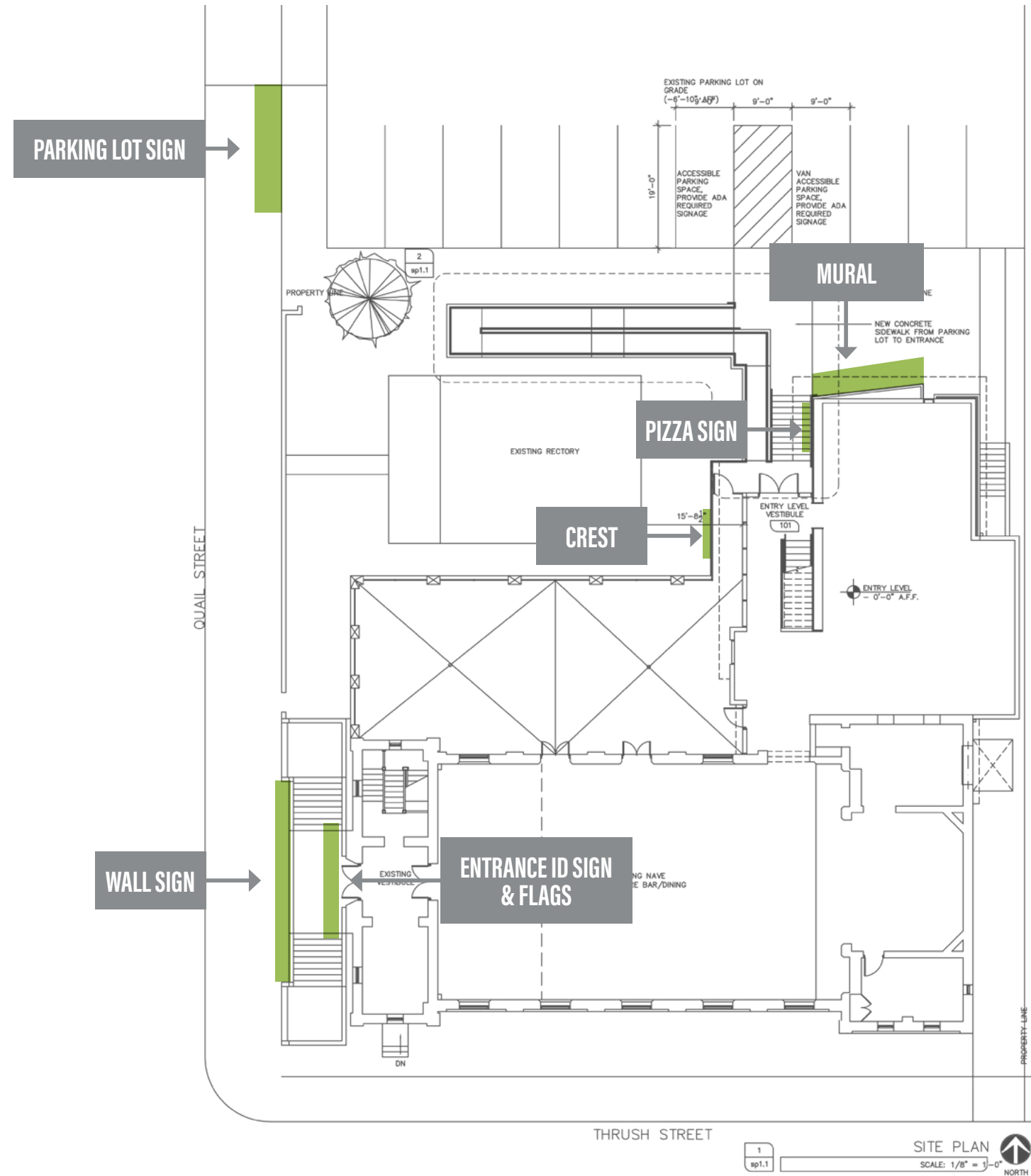

SIGNAGE PRELIMINARY DIMENSIONS

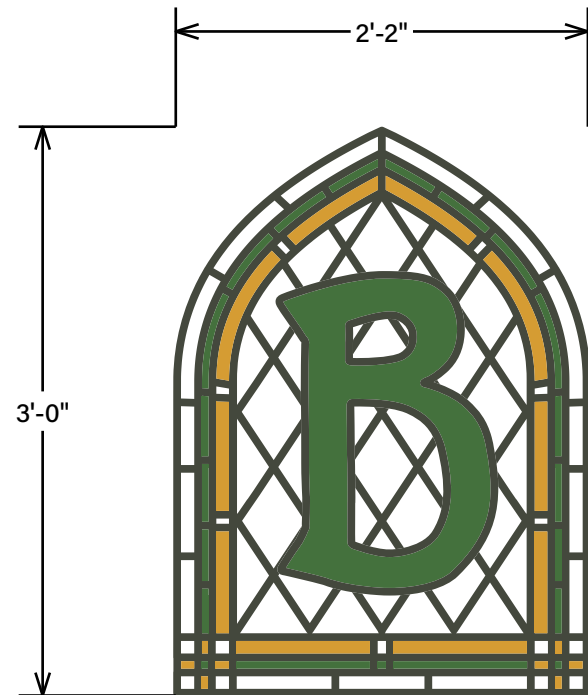

1 MAIN ENTRY CREST SIGN
1"=1'0"

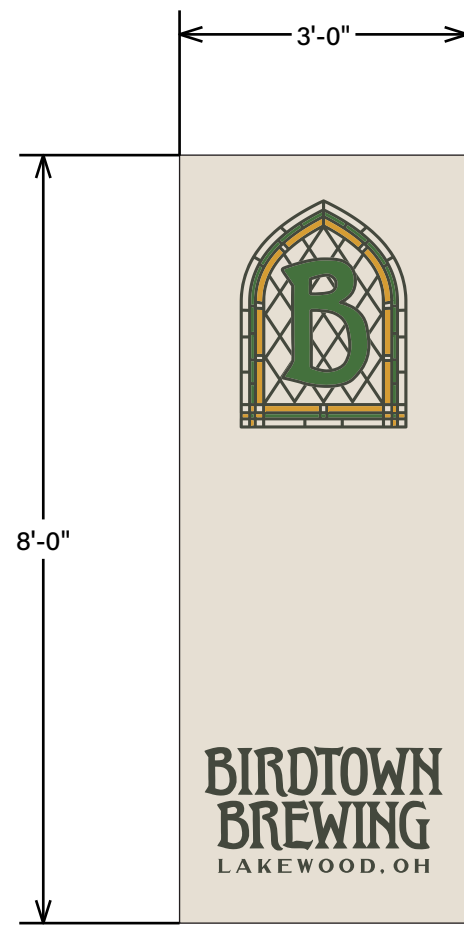

2 BIRDTOWN BREWING BANNER
1/2"=1'0"

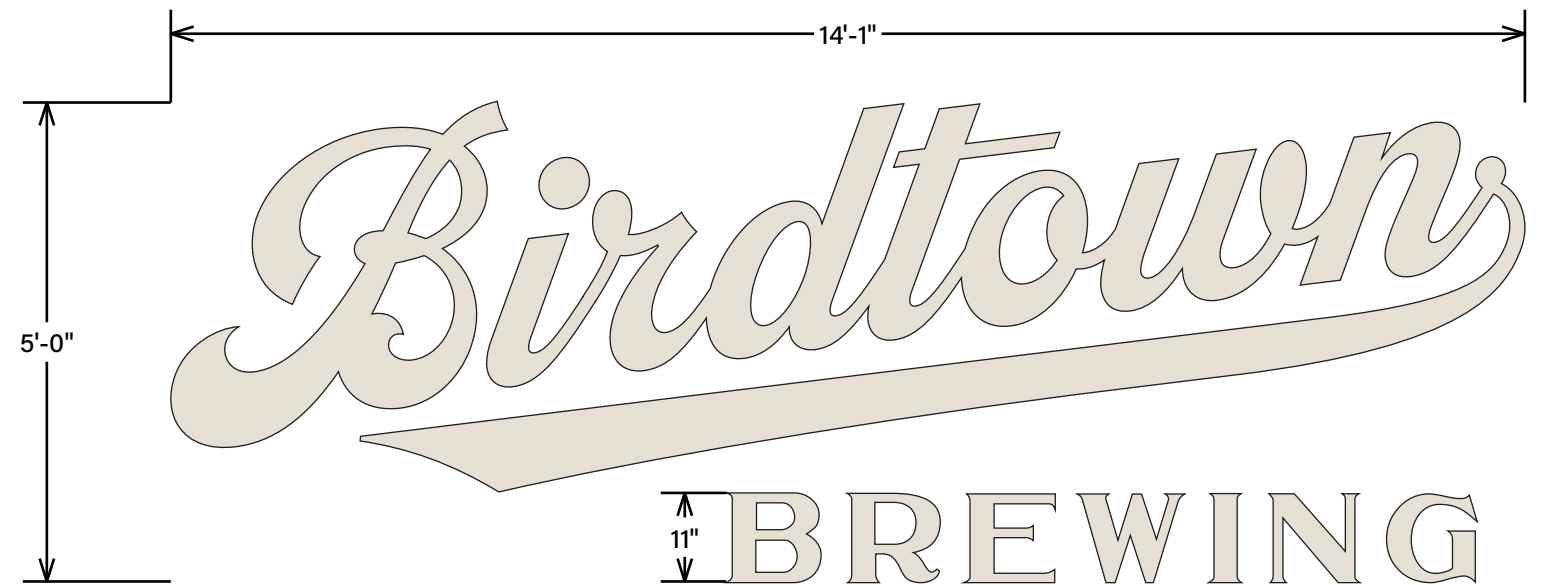

3 BIRDTOWN BREWING SCRIPT SIGN
1/2"=1'0"

SIGNAGE PRELIMINARY DIMENSIONS

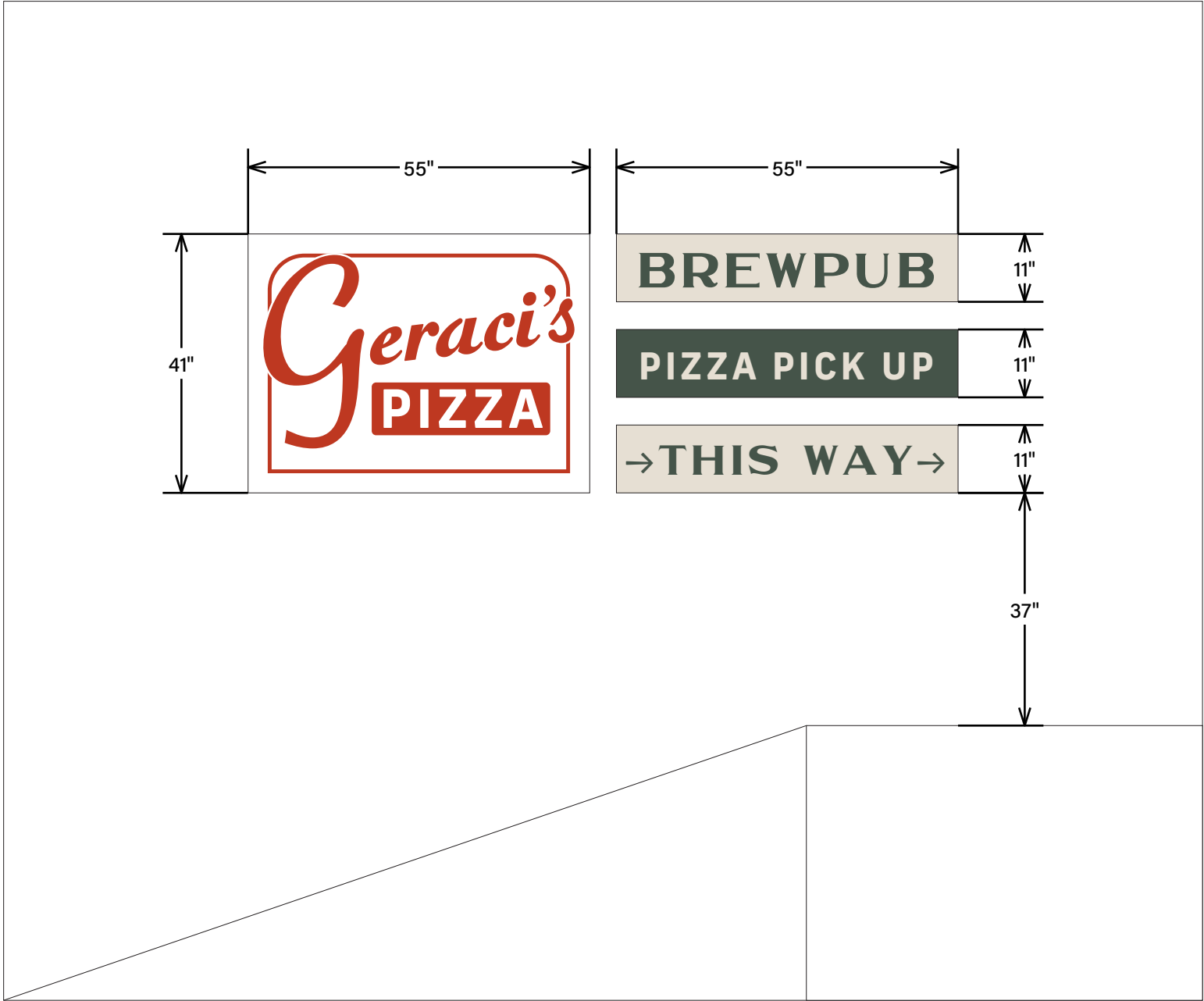

1 GERACI'S PIZZA PICKUP / BREWPUB ENTRY SIGNS
1/2"=1'0"

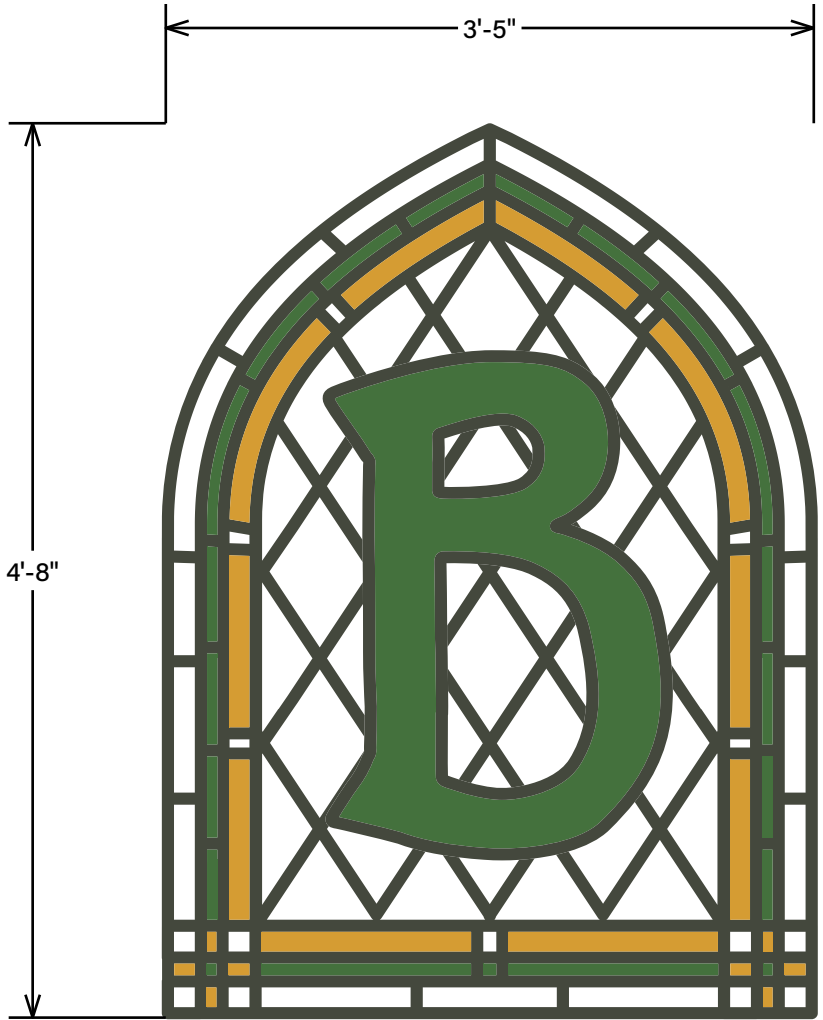

2 COURTYARD CREST SIGN
1"=1'0"

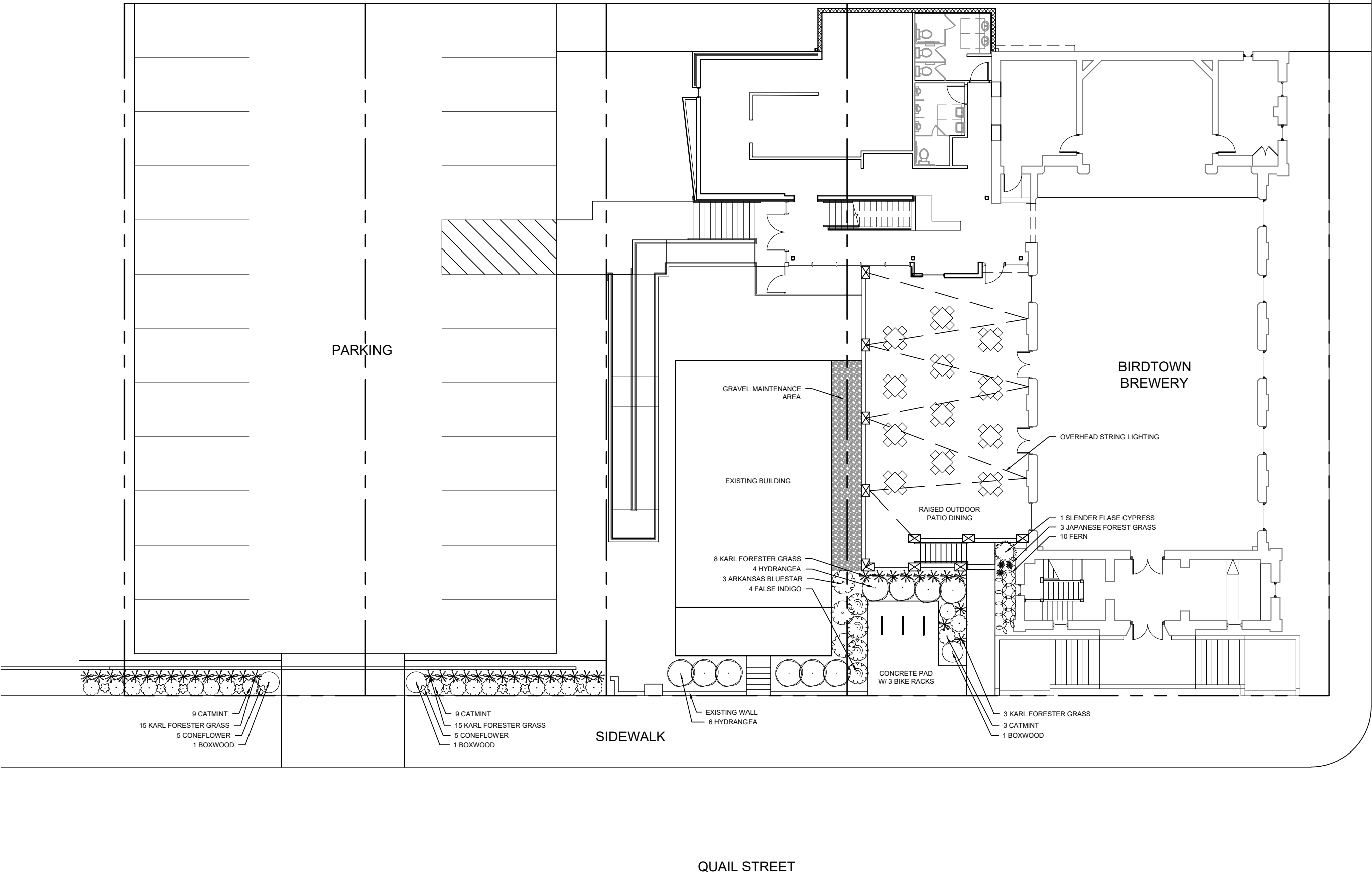

PARKING

BIRDTOWN
BREWERY

THRUSH STREET

GRAVEL MAINTENANCE
AREA

EXISTING BUILDING

RAISED OUTDOOR
PATIO DINING

OVERHEAD STRING LIGHTING

1 SLENDER FLASE CYPRESS
3 JAPANESE FOREST GRASS
10 FERN

8 KARL FORESTER GRASS
4 HYDRANGEA
3 ARKANSAS BLUESTAR
4 FALSE INDIGO

CONCRETE PAD
W/ 3 BIKE RACKS

3 KARL FORESTER GRASS
3 CATMINT
1 BOXWOOD

9 CATMINT
15 KARL FORESTER GRASS
5 CONEFLOWER
1 BOXWOOD

9 CATMINT
15 KARL FORESTER GRASS
5 CONEFLOWER
1 BOXWOOD

EXISTING WALL
6 HYDRANGEA

SIDEWALK

QUAIL STREET

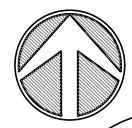



Perspective Rendering - View From Quail Street

Plant Palette



FALSE INDIGO



LADY IN RED FERN



KARL FOERSTER GRASS



BOXWOOD



BLUSHING BRIDE HYDRANGEA



SLENDER FALSE CYPRESS



ARKANSAS BLUESTAR



CONEFLOWER



CATMINT



JAPANESE FOREST GRASS

Landscape Elements



BIKE RACKS

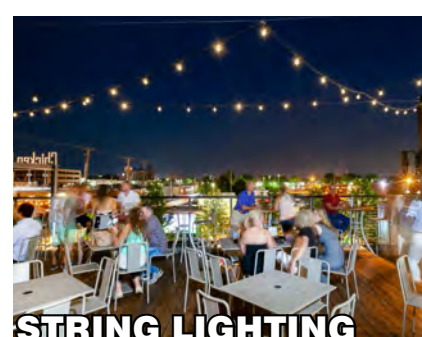

STRING LIGHTING



HANGING BASKETS



SEASONAL PLANTERS



**City of Lakewood
Department of Planning
and Development**

**Angela Byington, Director
David Baas, AICP, Asst. Director**

(216) 529-6630
planning@lakewoodoh.gov

March 18, 2026

Birdtown Brewing- Ryan Grammerstorf
2041 Marlowe Avenue
Lakewood , Ohio 44017

RE: Subject Matter : 2035 Quail

Outdoor Dining- Conditional Use Application -Planning Commission

Mr. Grammerstorf,

Thank you for your application for 2035 Quail , Outdoor Dining. More information is required, please see the list below. Let me know if you have any questions.

- A written description of the proposal and more photographs of the area to be occupied by the proposed outdoor dining area;
- A detailed, labeled and scaled site plan(please add a north arrow to site plan) and elevations of the location of the outdoor dining area showing, number and arrangement of tables and chairs, barriers, means of ingress and egress, sidewalk, above-ground utilities and any other sidewalk obstruction, parking and planter areas, fencing;
- An outdoor dining facility with a capacity of more than eight seats shall be included in the gross floor area square footage to determine parking space requirements per Chapter 1143. Current approval is for 23 parking spaces without outdoor dining. The additional square footage will require 2 more parking spaces, if the plan is to utilize on- street or other parking for the increase in required parking, please provide this information in the written description.
- Manufacturer's information and cut sheets on all proposed tables, chairs, barriers, lighting and accessory furniture; dimensions for furniture.
- A signed statement by the owner of the building confirming the ownership of the building and, if the owner is not the applicant, a signed statement granting permission to the applicant to pursue the conditional use permit; The owner of record is Sandy Banks LLC. Please send documentation establishing relationship to either Sandy Banks LLC, or documentation from someone establishing their relationship with Sandy Banks LLC and their authorization for you to speak on this matter on their behalf.
- Buffering with landscaping or fencing of the outdoor dining facility, if the facility is adjacent to residential or sensitive uses, may be required. Scaled elevations, photographs, etc. Show on site plan where buffering , landscaping or fencing will be and provided elevations of proposed.



**City of Lakewood
Department of Planning
and Development**

**Angela Byington, Director
David Baas, AICP, Asst. Director**

(216) 529-6630
planning@lakewoodoh.gov

-
- Serving alcohol requires compliance and approval from liquor control. Provide information about your communications with the liquor control agency and how you are fulfilling their requirements for Outdoor Dining.

Please let me know if you have any questions about the additional information requested.

Sincerely,

Michelle Nochta

216-529-5906

Michelle.nochta@lakewoodoh.gov



Specifications

03/10/2026

Project

~~XXXXXXXXXXXXXXXXXXXX~~

From

A1 RESTAURANT EQUIPMENT CO.
Julie Barnes
1838 E 55th Street
Cleveland, OH 44103
216-431-6665
(216)431-6665 (Contact)
(216)225-1366 (Cell)
216-431-6620 (Fax)
julie@a1cleveland.com
Url: a1cleveland.com

ITEM 1 - CHAIR (247 REQ'D)

Oak Street Model OD-CM-TK-G Dimensions: 33(h) x 17.44(w) x 18.13(d)

Dining Chair, Indoor/outdoor, gray synthetic teak plank back and seat, weather resistant, non-marring nylon glides, e-coated frame with silver powder coat finish, ships assembled (NOT suitable for oceanside or poolside applications)

- 1 ea **WARNING:** This product can expose you to chemicals known to the State of California to cause cancer, birth defects, and/or other reproductive harm. For more information go to www.P65Warnings.ca.gov
- 247 ea 1 yr. warranty against defects in material and workmanship, std.



ITEM 2 - TABLE, OUTDOOR (26 REQ'D)

Grosfillex Model US928288 Dimensions: 29.33(h) x 34(w) x 34(d)

Sigma Complete Outdoor Table, 34" x 34" x 29-1/3"H, square, slatted aluminum table, (4) corner legs with adjustable levelers, umbrella hole with plug, UV resistant, ships complete, textured finish, Volcanic Black, Made in China



ITEM 3 - TABLE, OUTDOOR (1 REQ'D)

Grosfillex Model US929288 Dimensions: 29.33(h) x 34(w) x 48(d)

Sigma Complete Outdoor Table, 48" x 34" x 29-1/3"H, square, slatted aluminum table, (4) corner legs with adjustable levelers, umbrella hole with plug, UV resistant, ships complete, textured finish, Volcanic Black, Made in China









EXIT

SKYJACK SJIII 3219

SKYJACK

SKYJACK

SKYJACK

STATE OF OHIO
DEPARTMENT OF COMMERCE
DIVISION OF LIQUOR CONTROL

00695533-1 NEW 1/30/2026 10/1/2026
 PERMIT NUMBER CODE DATE ISSUED EXPIRATION DATE

THIS CERTIFIES THAT
BIRDTOWN BREWING LLC
 2035 QUAIL ST
 LAKEWOOD OH 44107

THIS CERTIFICATE IS VALID ONLY BETWEEN THE DATE ISSUED AND EXPIRATION DATE APPEARING HEREIN. IT MAY BE USED ONLY BY THE NAMED HOLDER AT THE LOCATION FOR WHICH ISSUED.

THE PERSON NAMED HEREIN IS AUTHORIZED TO SELL OR DISPENSE ALCOHOLIC BEVERAGES WITH ALCOHOLIC CONTENT PERMITTED BY LAW FOR THE PERMITS DESIGNATED BELOW.

THIS CERTIFICATE AND/OR EACH TYPE OF PERMIT REPRESENTED IS SUBJECT TO SUSPENSION, REVOCATION OR CANCELLATION AS AUTHORIZED BY TITLE XXII OF THE REVISED CODE.

IS THE HOLDER OF PERMIT OR PERMITS DESIGNATED BELOW

18 Cuyahoga 18286 Lakewood 01/30/2026

CODE	PERMIT DESCRIPTION & FEE
A-1C	Manufacturer of beer, ale, stout and other malt liquor Fee Paid: \$1,000

Restrictions:

Sunday Privileges

PUR SPRT LQUR FROM AGY# 40925 WARREN VILLAGE BEVERAGE

For question about the status of this permit, visit com.ohio.gov/2000000

PERMITS AUTHORIZED BY SECTIONS 4303.01 TO 4303.112, INCLUSIVE OF THE REVISED CODE

4303.06 Obstructing work of premises prohibited. No person shall make or obtain any agent or employee of the division of liquor control, any enforcement agent of the department of public safety, or any officer of the law, from making inspection of records of any place other than a bona fide private residence, where beer or intoxicating liquor is possessed, kept, sold, or given away.

Sherry Maxfield

DIRECTOR OF COMMERCE

Jackie DeGenova

SUPERINTENDENT OF LIQUOR CONTROL

DIVISION OF LIQUOR CONTROL
PERMITEE IDENTIFICATION CARD

00695533-1 NEW 1/30/2026
 PERMIT NUMBER CODE DATE ISSUED
 10/1/2026 A-1C
 EXPIRATION DATE PERMIT CLASSES

BIRDTOWN BREWING LLC
 2035 QUAIL ST
 LAKEWOOD OH 44107

PUR SPRT LQUR FROM AGY# 40925
 WARREN VILLAGE BEVERAGE



Sherry Maxfield

DIRECTOR OF COMMERCE

Jackie DeGenova

SUPERINTENDENT OF LIQUOR CONTROL

MAY PURCHASE BEVERAGES AS INDICATED ABOVE

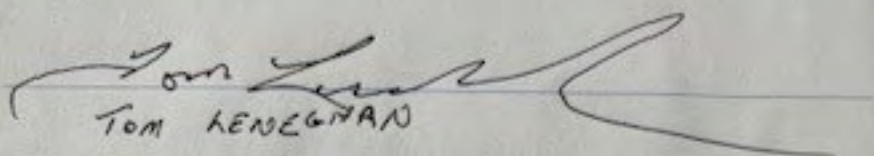
TOM LENEGHAN

I, Tom Leneghan am the sole owner of the property located at 2035 Quail Street in Lakewood,
Ohio

March 10, 2026



City of Lakewood
Planning Commission

(216) 529-6630
planning@lakewoodoh.gov

Application Cover Page

Docket No.: 04-08-26

Permit No.: PC26-000005

Applicant Name: George Gountis, Mars Bar

Project Address: 15314 Madison Ave.

Project Name: Mars Bar Sidewalk Dining 2026

Proposal: The review and approval for a conditional use permit to operate seasonal outdoor dining for a new private outdoor bar, pursuant to section 1129.13 – supplemental regulations for outdoor/ seasonal dining facility. (Ord. 33-2022. Passed 11-21-22.) The property is in the C2, Commercial Retail district.





City of Lakewood
Department of Planning
and Development

Angela Byington, Director
David Baas, AICP, Asst. Director

(216) 529-6630
planning@lakewoodoh.gov

March 10, 2026

Mars Bar
15314-15400 Madison Ave.
Lakewood, OH 44107

RE: Outdoor Dining: PROWAG adopted – New regulations impact your conditional use permit for sidewalk dining

Dear Business Owner,

An inspection has been conducted to evaluate the viability of using the public sidewalk in front of your business located at 15314-15400 Madison Ave. for seasonal outdoor dining.

The findings show that there is a portion of the sidewalk that is eligible to apply for conditional use for seasonal sidewalk outdoor dining from the Planning Commission, instructions attached.

- Width of remaining path of travel is measured from the edge of the utility area, it is never permitted to reduce the path of travel from the required 5 feet, stable, level travel surface, free of impediment.
- Width of dining area-**need to move west of the fire hydrant and 2 inches closer to the foundation.**
- Sidewalk must be maintained in compliant repair at all times or permission for sidewalk dining will be revoked.

Sincerely,

Michelle Nochta

Senior Planner and ADA Coordinator City of Lakewood, Ohio

Michelle.Nochta@lakewoodoh.gov

(216) 529-5906

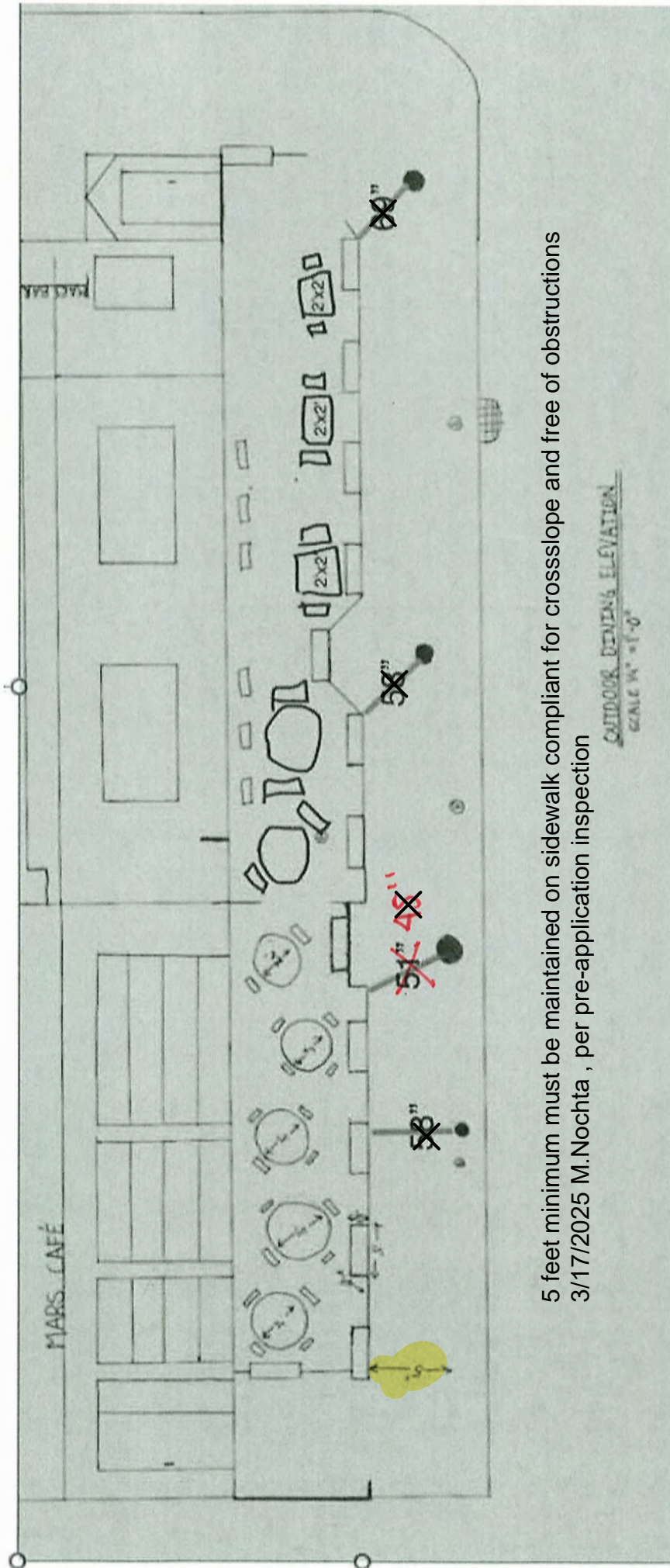

5 feet minimum must be maintained on sidewalk compliant for crossslope and free of obstructions
 3/17/2025 M.Nohta , per pre-application inspection

OUTDOOR DINING ELEVATION
 SCALE W = 1'-0"



City of Lakewood
Planning Commission

(216) 529-6630
planning@lakewoodoh.gov

Application Cover Page

Docket No.: 04-09-26

Permit No.: PC26-000006

Applicant Name: Sean Fairbairn, Barrio

Project Address: 15527 Madison Ave.

Project Name: Barrio Sidewalk Dining 2026

Proposal: The review and approval for a conditional use permit to operate seasonal outdoor dining for a new private outdoor bar, pursuant to section 1129.13 – supplemental regulations for outdoor/ seasonal dining facility. (Ord. 33-2022. Passed 11-21-22.) The property is in the C2, Commercial Retail district.

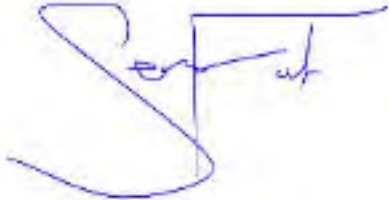

USE OF PUBLIC PROPERTY AGREEMENT
BY AND BETWEEN
THE CITY OF LAKEWOOD
AND
RESTAURANT

THIS AGREEMENT effective this 4th day of May, 2021, by and between the City of Lakewood, (hereinafter "the City"), 12650 Detroit Avenue, Lakewood, Ohio, 44107 and **Barrio**, (hereafter "RESTAURANT") 15527-33 Madison Avenue, Lakewood, Ohio 44107.

WHEREAS, Lakewood City Council approved the use of portions of the public right-of-way, upon approval of the Planning Commission, for outdoor dining by Ordinance No. 70-07, adopted March 2, 2009; and

WHEREAS, RESTAURANT operates a carry-out, delivery and dine-in eatery; and

WHEREAS, on **August 1, 2013** the Lakewood Planning Commission granted a Conditional Use Permit, attached as Exhibit "A", allowing RESTAURANT to utilize certain portions of the public right-of-way for an Outdoor/Seasonal Dining Facility adjacent to RESTAURANT's business establishment; and

WHEREAS, Lakewood Architectural Board of Review has administratively approved the outdoor design attached as Exhibit "B".

WITNESSETH:

For and in consideration of the mutual promises, covenants and agreements of the parties hereto as herein set forth, the parties hereby agree as follows:

1. **Term.** This agreement shall automatically renew annually upon approval of the Planning Commission and RESTAURANT's submission of the required proof of insurance to the CITY.

2. **Authorization.** The City of Lakewood hereby authorizes RESTAURANT to utilize certain portions of the public right-of-way, as defined by Exhibits A, for the establishment of an Outdoor/Seasonal Dining Facility as defined by Lakewood Zoning Code §1103.02, Definitions.

3. **Conditions.** RESTAURANT shall provide and maintain in good repair, furniture, fixtures and barriers as approved by the Architectural Board of Review and will make no modification to these elements without further approval by the Board as set forth in the diagram attached hereto as Exhibit "B. RESTAURANT must obtain permission of the Ohio Department of Liquor Control to serve alcoholic beverages on the Outdoor/Seasonal Dining Facility and must be in compliance with all applicable State, Federal and local laws at all times.

4. **Maintenance.** RESTAURANT shall clean the tables and benches, shall maintain all equipment and items placed in the public right of way or visible from the public right of way and located in an outdoor patio area in good and reasonable repair, and will immediately replace any and all broken, cracked, bent or otherwise defective equipment or items. RESTAURANT will maintain the entire Outdoor/Seasonal Dining Facility free from litter and refuse, will clean up the area at least four (4) times a day and will hose down the entire dining area at the beginning and at the close of each business day.

5. **Advertising.** There will be no advertising displayed on any of the tables, chairs, fixtures, barriers or other elements in the Outdoor/Seasonal Dining Facility.

6. **Hours of Operation.** RESTAURANT will ensure that the use of the Outdoor/Seasonal Dining Facility will be permitted only during the hours of 11:00 a.m. through 10:00 p.m. Sunday through Thursday,

**FOURTH ADDENDUM TO THE
USE OF PUBLIC PROPERTY AGREEMENT
BY AND BETWEEN
THE CITY OF LAKWOOD
AND
TRES AMIGOS LAKEWOOD LLC, DBA BARRIO LAKEWOOD**

THIS ADDENDUM entered into this 7 day of October, 2020, by and between the City of Lakewood, (hereinafter "the City"), 12650 Detroit Avenue, Lakewood, Ohio, 44107 and TRES AMIGOS LAKEWOOD LLC dba BARRIO LAKEWOOD (hereafter "RESTAURANT") 15527-33 Madison Avenue, Lakewood, Ohio 44107 modifies the Use of Public Property Agreement by and Between the City of Lakewood and Barrio Lakewood dated May 1, 2016 (hereinafter "Agreement").

WHEREAS, on August 1, 2013 the Lakewood Planning Commission granted a Conditional Use Permit, which was renewed at its May 7, 2020 meeting allowing Restaurant to utilize certain portions of the public right-of-way for an Outdoor/Seasonal Dining Facility. Now therefore,

WITNESSETH:

For and in consideration of the mutual promises, covenants and agreements of the parties hereto as herein set forth, the parties hereby agree to modify the Agreement as follows:

1. **Term.** The term of the agreement is extended through March 31, 2021.

CITY OF LAKEWOOD

Date _____

By: _____

Katelyn Z. Milius
Acting Director, Planning and Development

TRES AMIGOS LAKEWOOD LLC
dba BARRIO LAKEWOOD

Date 10/17/20

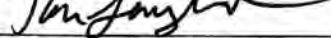
By: 

Tom Leneghan, Owner

APPROVED AS TO LEGAL FORM:

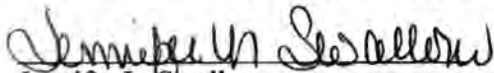

Jennifer L. Swallow
Chief Assistant Director of Law

11:00 a.m. Friday through 1:00 a.m. Saturday and 11:00 a.m. Saturday to 1:00 a.m. Sunday pursuant to Lakewood Zoning Code §1129.13(f).

7. **Insurance.** RESTAURANT shall provide the City certificates of insurance naming the City of Lakewood as an additional insured on policies of insurance having, at a minimum, the following coverages:

Non-liquor establishments:

General Liability \$1M per occurrence/\$2M aggregate
Premises Liability \$1M per occurrence/\$2M aggregate

Liquor establishments & Parklets:

General Liability \$1M per occurrence/\$2M aggregate
Premises Liability \$1M per occurrence/\$2M aggregate
Liquor Liability \$1.5
Umbrella \$1M (including liquor liability)

8. **Indemnification.** RESTAURANT shall defend, indemnify and hold the CITY, its officers, its officials, agents and employees, completely harmless from and against any and all liabilities, losses, suits, claims, judgments, fines or demands of every kind and nature (including all reasonable costs and expert fees) arising by reason of bodily injury, death of any person, damage to property, arising out of, as a consequence of, or incidental to the acts and omissions of RESTAURANT, RESTAURANT's officers, agents, employees, licensees or invitees, in the operation of an Outdoor/Seasonal Dining Facility within the public right-of-way as provided in this Agreement. Upon determination of the CITY, its officers, officials, agents and employees, RESTAURANT shall defend, indemnify and hold the CITY harmless from any and all liabilities, losses, suits, claims, judgments, fines or demand of every kind and nature arising by reason of RESTAURANT's operation of an Outdoor/Seasonal Dining Facility resulting from any claim of discrimination.

RESTAURANT shall defend all suits brought upon such claims and lawsuits and shall pay all costs and expenses incidental thereto, but the CITY shall have the right, at its option, to participate in the defense of the suit, without relieving RESTAURANT of any of its obligations hereunder. This paragraph shall survive expiration or early termination of this Contract.

9. **Termination.** This Agreement may be terminated upon thirty (30) days written notice by the City at any time if it determines, in its sole discretion, that the use is impairing pedestrian traffic or causing a nuisance. In addition, the Director of Planning and Development may terminate this agreement for any event of default under this agreement after giving RESTAURANT written notice of the default and a period of not less than ten (10) days to cure the default. An event of default shall constitute the failure to comply with any provision of this Agreement, the Conditional Use Permit issued by the Planning Commission (Exhibit A), plans or specifications approved by the Architectural Board of Review (Exhibit B), or the violation of any Federal, State or local regulation. Upon the issuance of notice of termination, RESTAURANT shall have five (5) business days to remove any portion of the Outdoor/Seasonal Dining Facility from the public right-of-way and restore the public right-of-way to the condition in which it existed prior to the creation of the Outdoor/Seasonal Dining Facility. Such restoration shall be subject to the approval of the Director of Public Works or his or her designee.

10. **Transferability.** This agreement is not transferable and shall not be assigned by either party.

11. **Renewal.** Subject to the City's right to terminate at any time as set forth above, this Agreement may be renewed annually. In the event RESTAURANT is interested in renewing this Agreement, it shall send written notice of its intent to renew along with the required certificates of insurance to the City no later

than 30 day prior to the expiration of the Conditional Use Permit. In the event the RESTAURANT desires to change its hours or any other terms of this Agreement, such changes must be approved by the Planning Commission.

12. **Entire Agreement.** This Agreement supersedes any and all other agreements, either oral or in writing, between the parties hereto with respect to the subject matter hereof, and no other agreement, statement, or promises relating to the subject matter of this Agreement that is not contained herein shall be valid or binding.

13. **Governing Law and Venue.** The construction and interpretation of the provisions of this Agreement shall be governed by the laws of the State of Ohio. RESTAURANT and City agree that any litigation or dispute over any matter related to or arising from this Agreement or the performance or lack thereof, its terms and/or conditions shall be solely and exclusively venued in the Cuyahoga County Court of Common Pleas, Cuyahoga County, Ohio. RESTAURANT hereby irrevocably consents and submits to the exclusive jurisdiction of this court in any such action, suit or proceeding relating to or arising under this Agreement, and further agrees that any such action, suit or proceeding shall be brought only in such court. RESTAURANT also waives any objection to this Court's personal jurisdiction over him/her/it and waives any objection to the jurisdiction of such court based upon *forum non conveniens* or any other objection to venue therein. RESTAURANT further consents to service of process as if RESTAURANT was a resident of Ohio and had been lawfully served with process in such jurisdiction.

14. **Amendment.** This Agreement may be amended by the mutual agreement of the parties hereto in a writing to be attached to and incorporated into this Agreement.

15. **Legal Construction.** In the event that anyone or more of the provisions contained in this Agreement shall for any reason be held invalid, illegal, or unenforceable, it shall not affect any other provision and this Agreement shall be construed as if the invalid, illegal or unenforceable provision had never been contained herein.

16. **Notices.** Any notice required by this Agreement or given in connection with it, shall be in writing and shall be given to the appropriate party by personal delivery or by certified mail, postage prepaid, or recognized overnight delivery services.

If to Restaurant:
Barrio Lakewood aka Tres Amigos
15527-33 Madison Avenue
Lakewood, Ohio 44107

If to City:
City of Lakewood
Director of Planning and Development
12650 Detroit Avenue
Lakewood, OH 44107

17. **Exhibits.** The following list of exhibits are incorporated as if fully rewritten herein:
A. Conditional Use Permit
B. Architectural Board of Review Approvals/Diagram

Executed at Lakewood, Ohio on the day and year first above written.

CITY OF LAKEWOOD

Date _____

By: _____
Katelyn Milius, Acting Director
Planning and Development

Barrio

Date 5/14/21

By: *Alan Farkas*
Barrio Lakewood aka Tres Amigos, Owner

APPROVED AS TO LEGAL FORM:

Jennifer L. Swallow

Jennifer L. Swallow
Chief Assistant Director of Law

P
Speci
AFI

To Whom It May Concern:

I, the undersigned, hereby authorize Barrio to apply to the Lakewood Planning Commission for a temporary outdoor dining permit. This authorization is for the restaurant located at 15527 Madison Avenue in Lakewood. If you have any questions or concerns please contact me.

Sincerely,

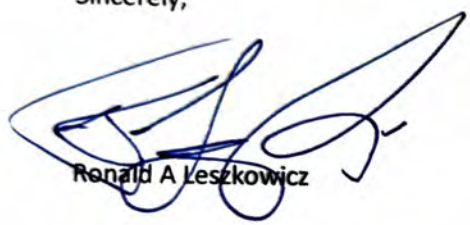

Ronald A Leszkowicz

216-272-3763

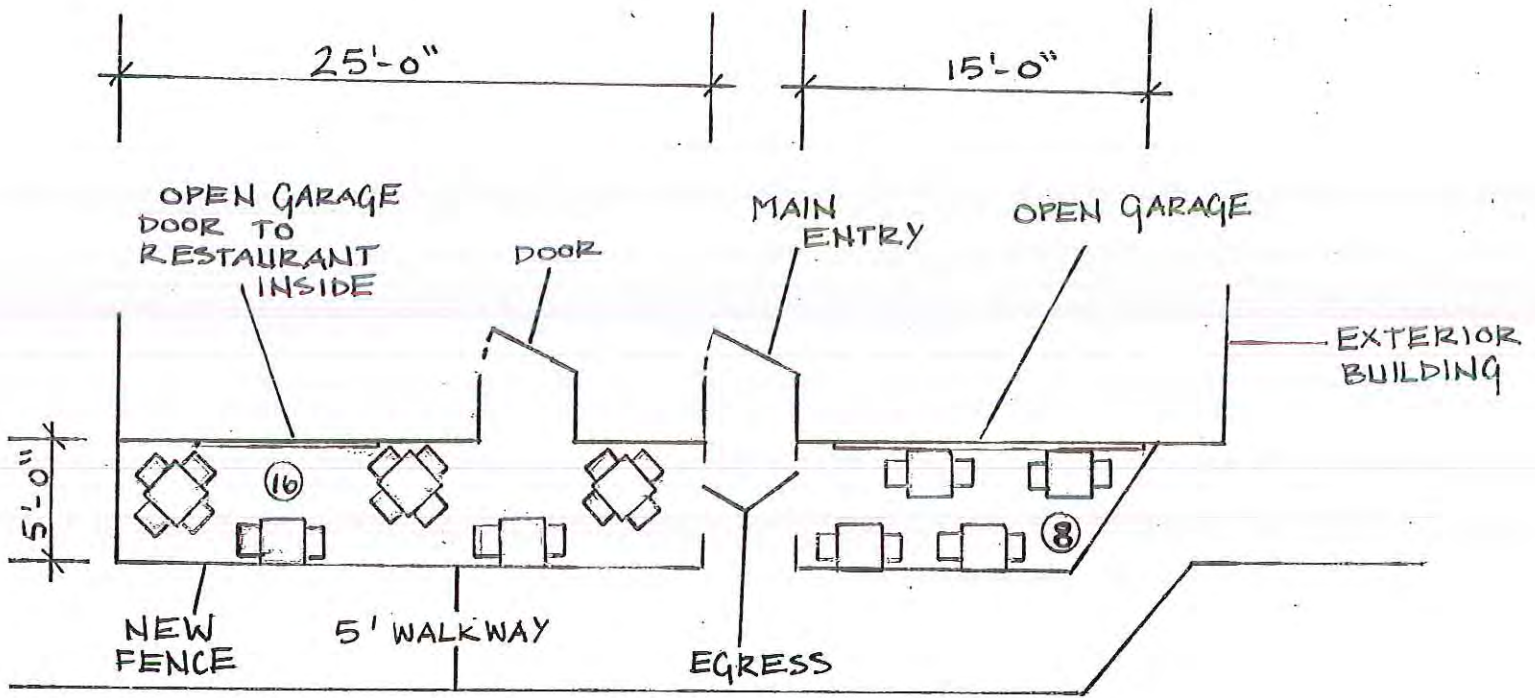

$\frac{1}{8}'' = 1'-0''$
 OUTDOOR PATIO

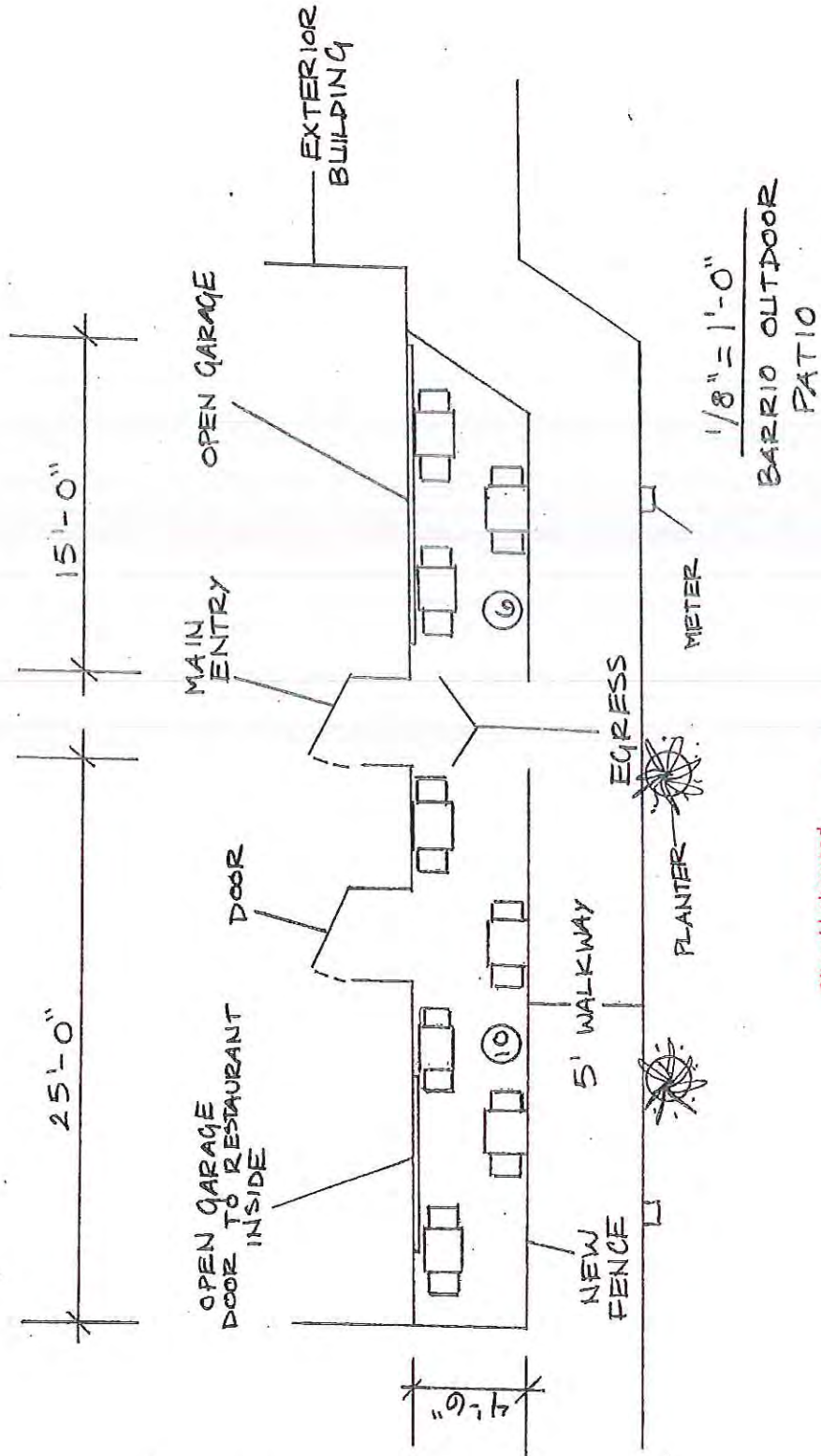

City of Lakewood
 Architectural Board of Review
 Approved as set forth in the minutes

of SEP 12 2013 meeting.

Carl Olson
 CHAIRMAN

Date: 5.22.13 /1	Design	Designer: Elisc Masaoaka
	EM	

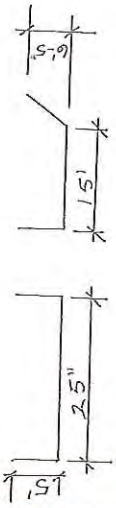
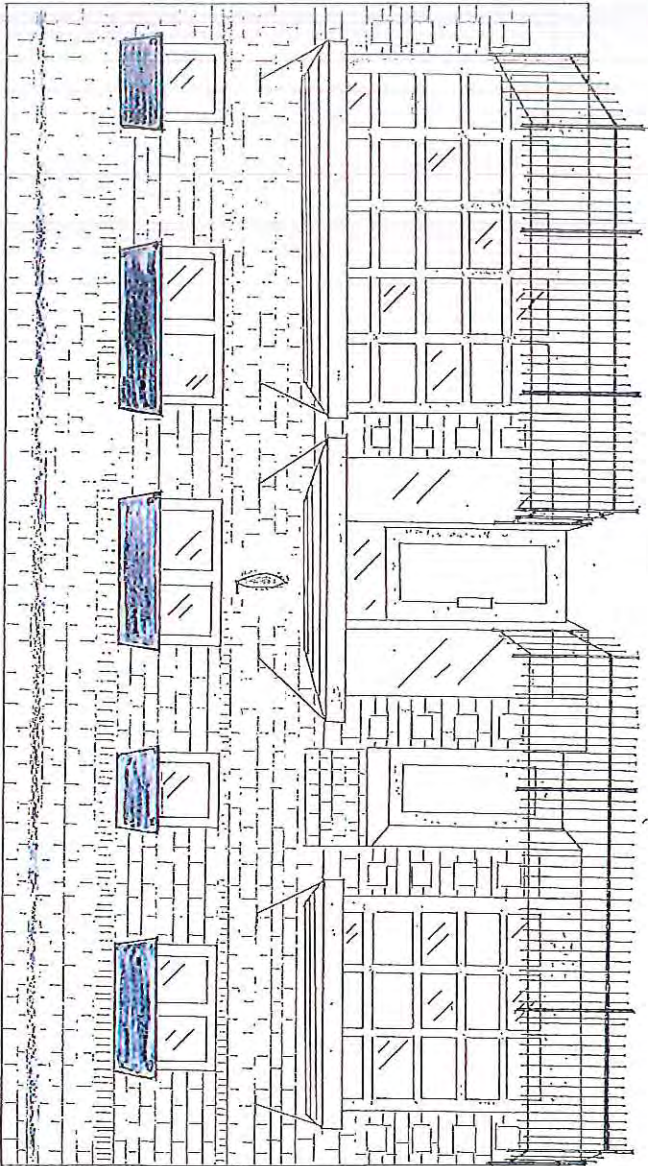

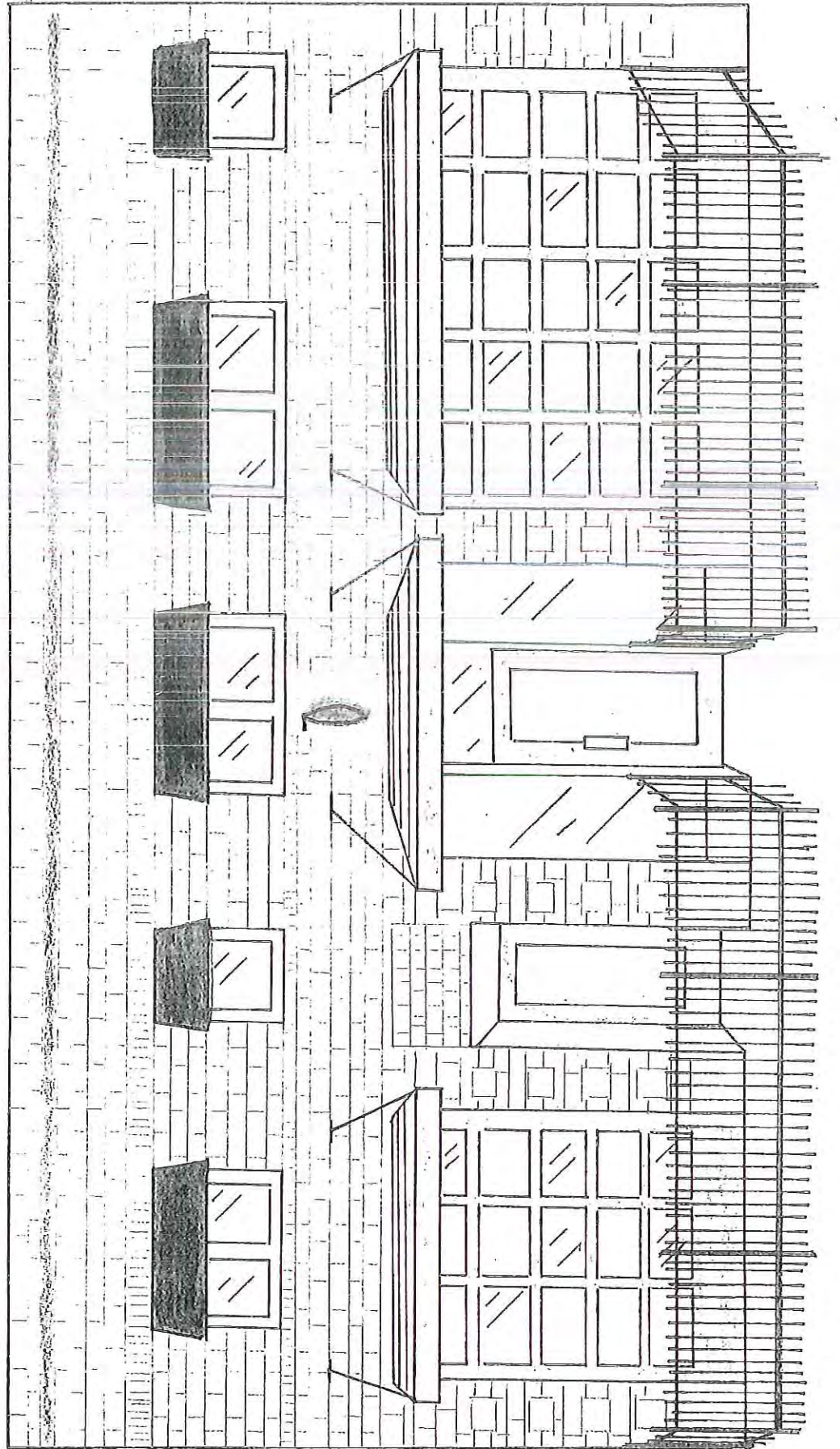
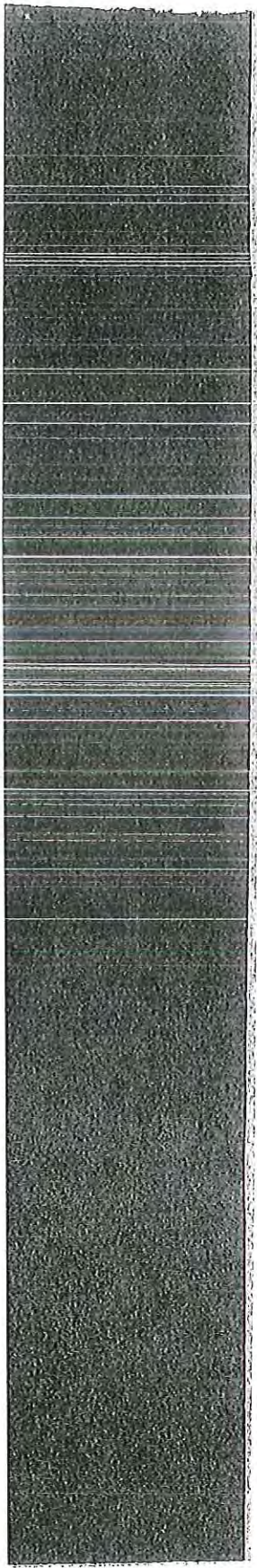

5-9

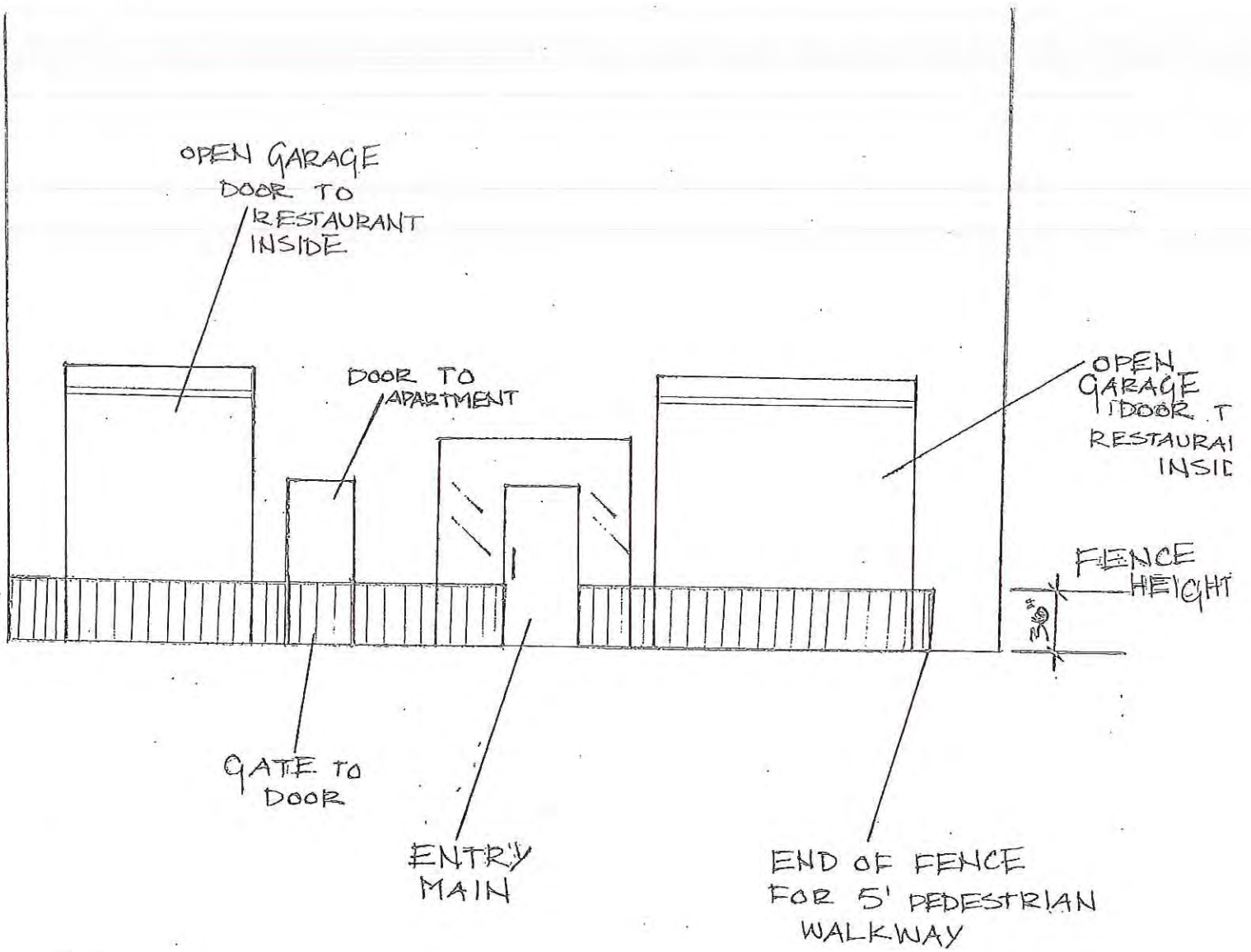



Sapphire Blue

Mocha

Red

Natural

Yellow

Purple

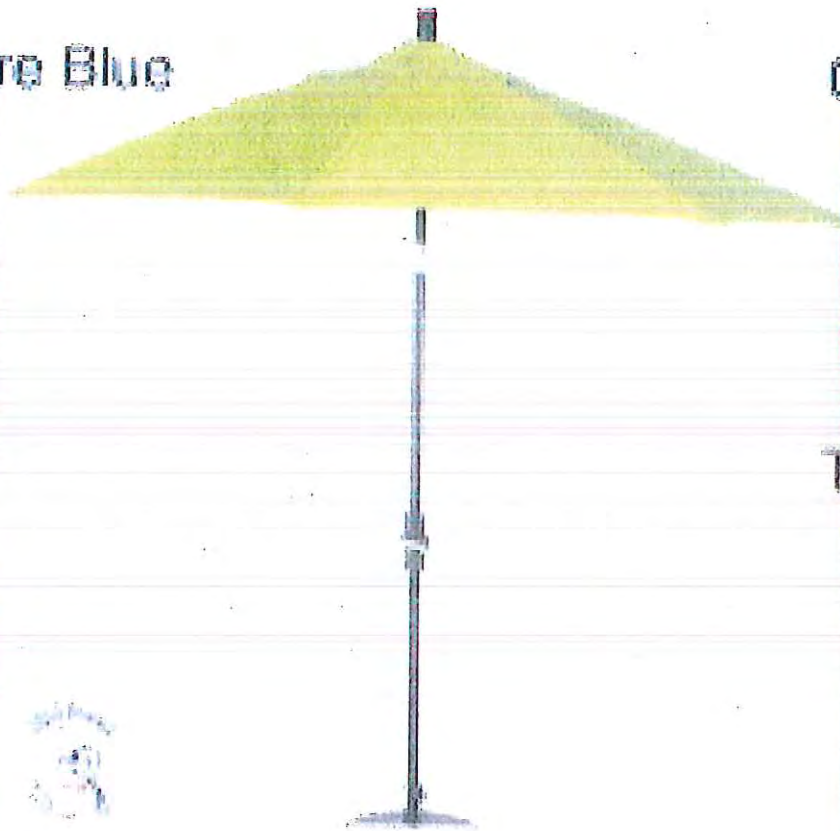

Ginkgo

Black

Capri

Tuscan

Straw

Spa





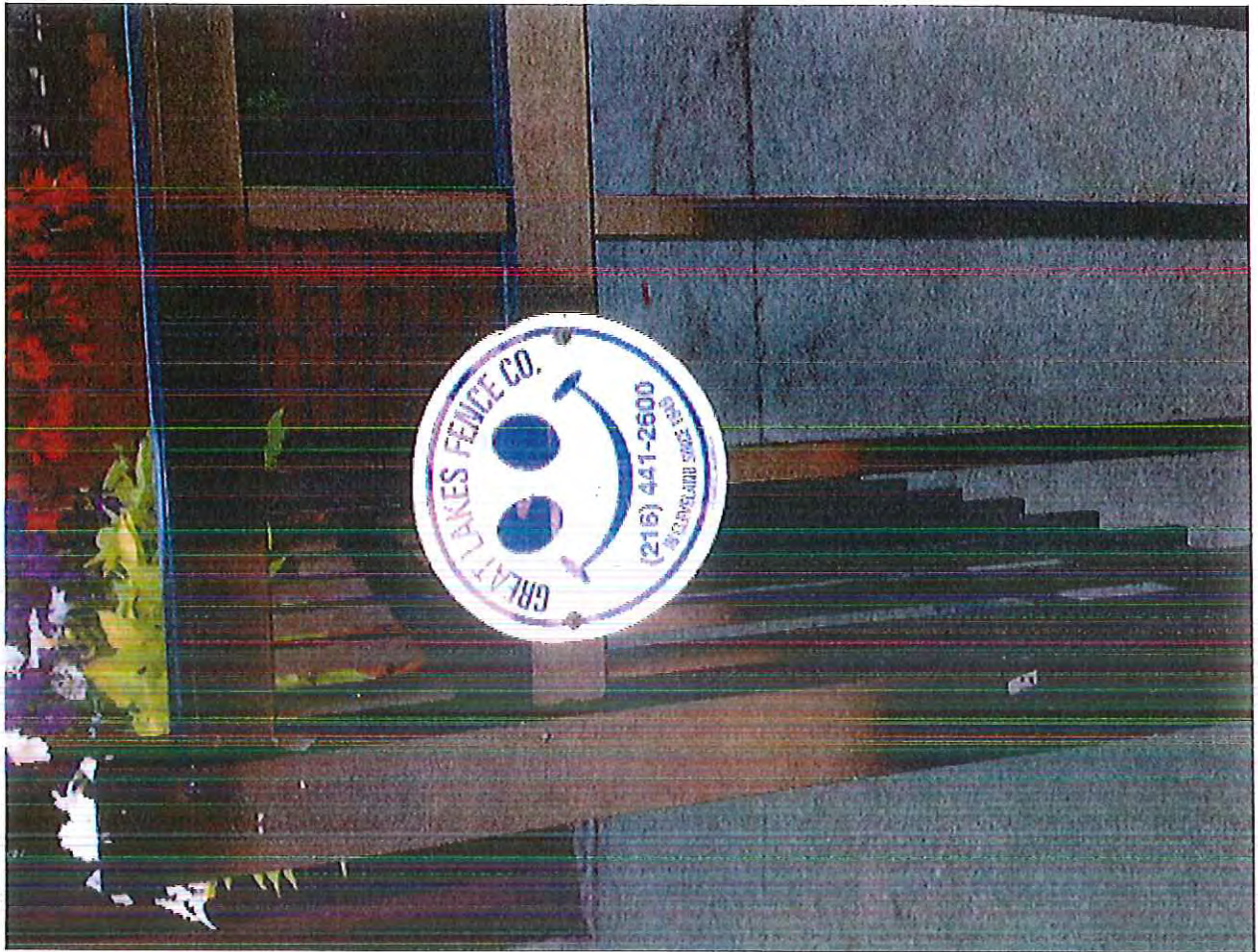





City of Lakewood
Planning Commission

(216) 529-6630
planning@lakewoodoh.gov

Application Cover Page

Docket No.: 04-10-26

Permit No.: PC26-000007

Applicant Name: Laura Ross, Cleveland Vegan

Project Address: 17412 Detroit Ave.

Project Name: Cleveland Vegan Sidewalk Dining 2026

Proposal: The review and approval for a conditional use permit to operate seasonal outdoor dining for a new private outdoor bar, pursuant to section 1129.13 – supplemental regulations for outdoor/ seasonal dining facility. (Ord. 33-2022. Passed 11-21-22.) The property is in the C2, Commercial Retail district.

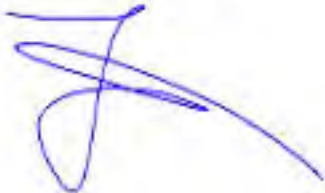



Dear City of Lakewood Planning Commission:

Thank you for giving us the opportunity to submit this plan. We appreciate your openness to helping the businesses of Lakewood.

Cleveland Vegan is proposing a temporary outdoor dining request that entails adding four (4), 30"x30" tables with two seats on either side of each table to our current storefront.

Thank you for your time,

Laura T. Ross
Owner, Cleveland Vegan
3/13/26

Justin A. Gorski
Owner, Cleveland Vegan
3/13/26

17112 Detroit Ave
Lakewood, OH 44107
216-832-7440
clevelandvegan.com

Cleveland Vegan Temp. Outdoor Dining - 17112 Detroit Ave

Sidewalk 7' wide

Left storefront usable space - 11'

Right storefront usable space - 18'

Right storefront unused doorway cove - 5' wide x 7 1/2' deep

*proposing 4 tables for storefront. Each table is 3' x 3' *

#216.832.7440

- Laura Ross
(owner)

ClevelandVegan@gmail.com

Le Salsa

17108 →
Detroit Ave.

← Cle. Vape
17114 Detroit Ave.

New tables are 24" inches in width

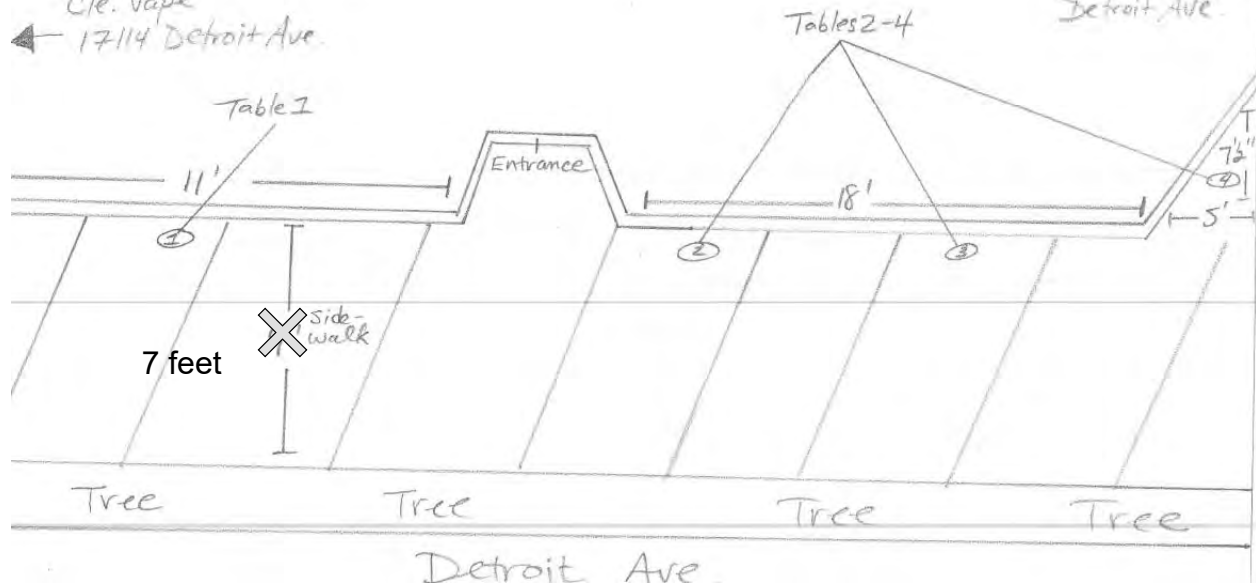

5 feet minimum of compliant sidewalk must be kept clear, leaving 2 feet for outdoor dining. Per Pre-application inspection there is 7 feet of compliant sidewalk currently, can be reevaluated once sidewalk repairs are complete. M. Nocht 3/17/2026







35





City of Lakewood
Planning Commission

(216) 529-6630
planning@lakewoodoh.gov

Application Cover Page

Docket No.: 04-11-26

Permit No.: PC26-000008

Applicant Name: Evan Laisure, The Pastimes Cafe

Project Address: 14224 Madison Ave.

Project Name: The Pastimes Cafe Sidewalk Dining 2026

Proposal: The review and approval for a conditional use permit to operate seasonal outdoor dining for a new private outdoor bar, pursuant to section 1129.13 – supplemental regulations for outdoor/ seasonal dining facility. (Ord. 33-2022. Passed 11-21-22.) The property is in the C3, Commercial General district.

12

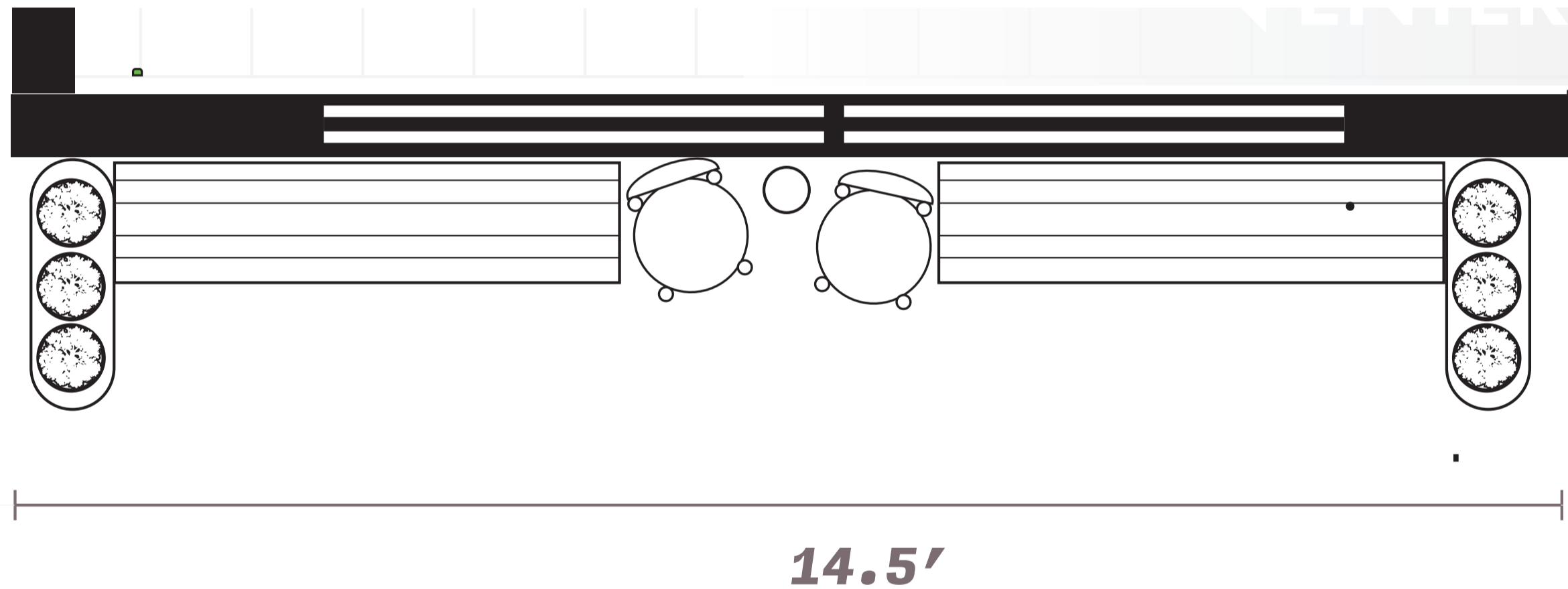
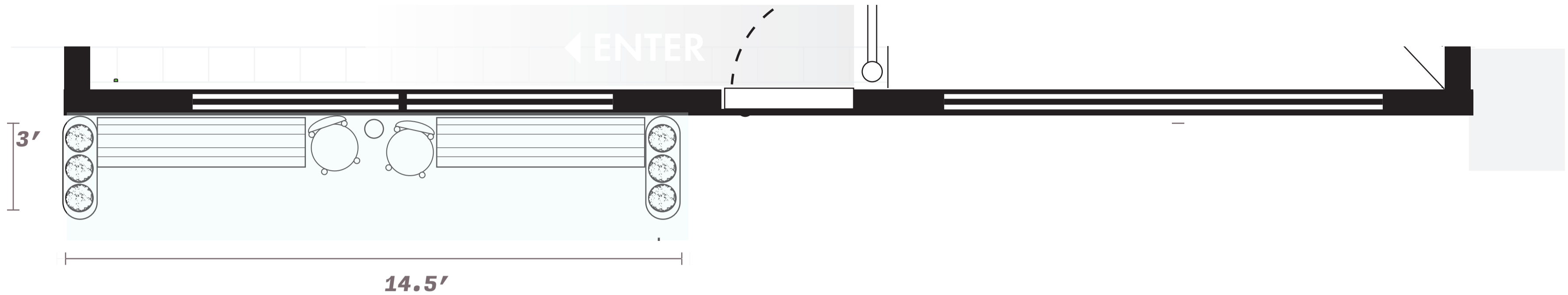

C. PATIO REVISED

Overhead view of the patio in accordance with the allowed section based off our inspection:



Width of dining area:
3 feet from the foundation and west of the entryway.

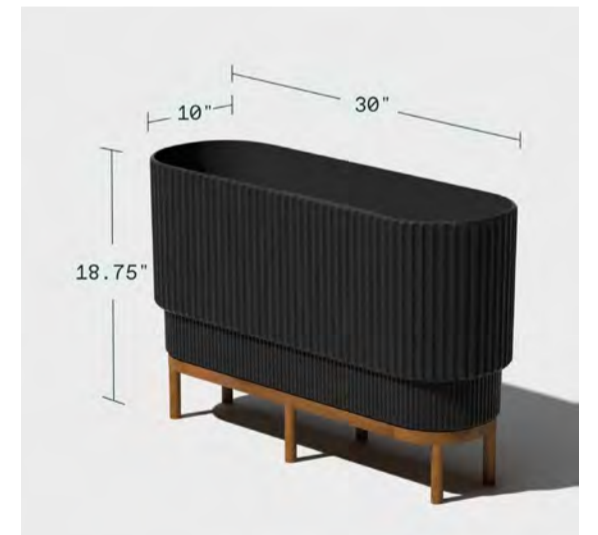

Weight Capacity: 880lbs

